

QUALITY CHANGES THE WORLD

**PRODUCT
SPECIFICATIONS**



STC600T5

**SANY TRUCK CRANE
60T LIFTING CAPACITY**



**Max. Lifting Capacity: 60t
Max. Boom Length: 45.5m
Max. Lifting Moment: 2107kN-m**

L/R HAND DRIVE BOTH AVAILABLE

www.sanyglobal.com

V1.8

SANY TRUCK CRANE STC600T5 / 60T LIFTING CAPACITY

More user friendly cab



- Five section boom welded by high tensile steel plate, 2m longer than old generation. Larger cross section structure reduces bending compact.



- Crane motions controlled electronically.
- Newly shaped instrument panel and armrest box, adopting sedan-class "peach wood grain", simple yet eye pleasing.
- Panoramic skylight with rollable sunshade, wide adjustable seat, 3D airflow AC, enhancing comfort.
- One button switch of eco and strong modes.



7"HD E-touch, optimized display of every working condition



- 0~20° tiltable cab, relieving fatigue in long time operation.
- 45° tilted membrane buttons, easy to view and touch.

All-round safety system

- Motion of risks are cut off automatically with buzzer warning.
- Self-developed LMI, auto-warning for overload.
- Hydraulic balance valve, relief valve, two-way pilot-controlled valve are reasonably placed to ensure system reliability.
- Three-circle protector at main and aux. winches, preventing wire rope from over-hoist down.
- Height limit switch at head of boom and fixed jib, preventing wire rope from over-hoist up.





Two stage outrigger

- Front outriggers beams are positioned lower for more stable support and more reasonable stress distribution.
- Newly developed half extension mechanism makes the crane more adaptable to work at constricted area.
- G-class chassis, adaptable for multiple road conditions. The carrier empowers the whole machine with more possibilities for operation in various jobsites, making traveling a more comfortable experience for the driver.

Counterweight – balance of performance and convenience

- Fixed unit: 4.8t
- Movable unit: 3.2t
- Integrated lifting cylinder, easy to install and remove.
- With overall compact design, the crane still has plenty of place for access and storage.



Overall Dimensions

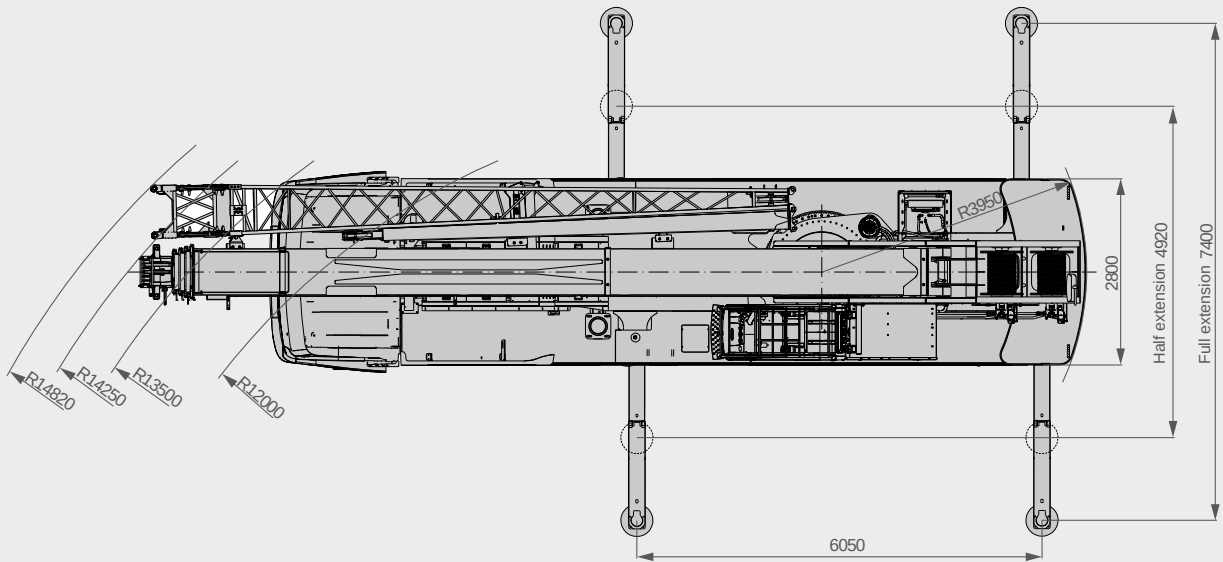
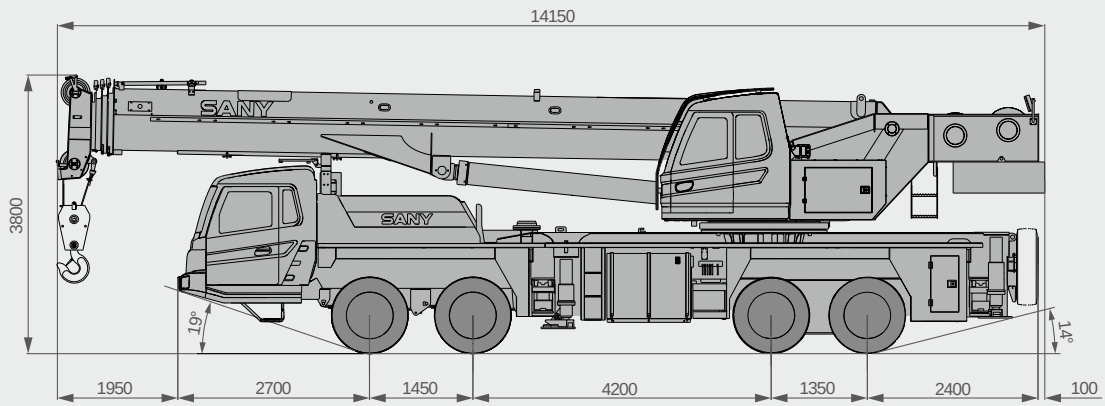

Technical Specification

CATEGORY	ITEM	UNIT	VALUE	
CAPACITY	Max. lifting capacity	t	60	
WEIGHT	Gross weight	kg	42500	
POWER	Engine model	-	CUMMINS ISLe340 30 (Euro III)	
	Max. engine power	kW/rpm	250/2100	
	Max. engine torque	N·m/rpm	1425 (1100~1400)	
DIMENSIONS	Overall length	mm	14150	
	Overall width	mm	2800	
	Overall height	mm	3800	
TRAVEL	Max.travel speed	km/h	85	
	Steering radius	Min.steering radius	m	12
		Min.steering radius of boom tip	m	14.8
	Wheel formula	-	8×4	
	Min.ground clearance	mm	245	
	Approach angle	°	≥19	
	Departure angle	°	≥14	
	Max.gradeability	-	47%	
	Fuel consumption per 100km	L	≤40	
	MAIN PERFORMANCE	Working temperature range	°C	-20~45
Min.rated lifting radius		m	3	
Tail slewing radius		m	3.95	
Boom sections (Qty.)		-	5	
Boom shape		-	U shape	
Max.lifting moment		Basic boom	kN·m	2107
		Full-extension boom	kN·m	1287
		Max.combination of boom + jib	kN·m	633.5
Boom length		Basic boom	m	11.74
		Full-extension boom	m	45.5
		Max.combination of boom + jib	m	61.5
Max.lifting height		Basic boom	m	12.1
		Full-extension boom	m	46
	Max.combination of boom + jib	m	62	
Outrigger span (Longitudinal×Transverse)	m	6.05×7.4		
Jib offset	°	0/15/30		
AIRCONDITIONER	in operator's cab	-	Heating & cooling (LHD) Cooling (RHD)	
	in driver's cab	-	Heating & cooling	

Technical Parameters



Axle Load

Axle	1	2	3	4	Gross weight
Axle load/t	8.25	8.25	13	13	42.5



Hook

Rated load/t	Number of sheaves	Rope rate	Hook weight /kg
60	6	12	550
6	/	1	120



Operations

Item	Max.single rope lifting speed (empty load)	Rope diameter/length	Max. single line pull
Main winch	135m/min	18mm/215m	5t
Auxiliary winch	125m/min	18mm/135m	5t
Slewing speed	0~2r/min		
Full luffing up/ down time of boom	50s/90s		
Full extension/ retraction time of boom	100s/100s		
Jack outrigger	Retraction	35s	
	Extension	35s	
beam outrigger	Retraction	20s	
	Extension	20s	

Crane Introduction

superstructure



Operator's cab

- The cab is designed 0°-20° tiltable in Ergonomic concept with deep consideration of convenience, safety, and comfort. Corrosion resistant bodywork with softened interior trim. The skylight, adjustable seat, air conditioning, electric windshield wiper, and 7" touch screen make working on the crane more comfortable.



Boom & telescoping system

- U shape cross section welded by high strength structural steel. Telescoping is realized by two cylinders with rope arranger.



Hoist

- Hoist smoothness is guaranteed by the perfect combo of winch balance valve and anti-slip tech. In the process of hoisting, energy cost is reduced via double variable mechanism.
- Main hoist is driven by electric proportional variable motor, stepless speed regulation available.



Luffing system

- Passive luffing down with balance system, reducing energy cost yet raising stability. Luffing angle: -2°-80°.



Hydraulics

- The combined motion performance is optimized by over 50% via all new double pump system which is applied at all T-series truck cranes.
- The control precision and stability are of higher level via load-sensing piston pump and electric main valve.
- Remarkable slewing inching motion performance with free-slip function.
- Dynamic compensated passive luffing down enables luffing at a constant speed without extra shock.



Slewing

- Electric control. The crane slewing brakes smoothly via balance design.



Control system

- Safety guarantee: SANY, Load Moment Indicator providing all-round protection.
- Fault diagnosis: BCM controller for fault detection and easy maintenance.
- Colored display & smart panel & IO power distribution: user friendly.
- Specially developed battery set: smarter electricity distribution.
- T-box: cloud fleet management regarding machine movement, load conditions, statistics and big data analysis.



Counterweight

- Fixed CW 4.8t. Movable CW 3.2t.



Safety equipment

- Self-developed LMI.
- Hydraulic balance valve, relief valve, two-way pilot-controlled valve.
- Three-circle protector at main and aux. winches, preventing wire rope from over-hoist down.
- Height limit switch at head of boom and fixed jib, preventing wire rope from over-hoist up.
- An all-round safety system covers load moment (LMI), hydraulics, winch, and wire rope. Motion of risks are cut off automatically with buzzer warning.



Optional equipment at extra fees

- Fire extinguisher with bracket.
- Slewing buzzer.
- Boom angle indicator.
- Outrigger pad.
- Heating in operator's cab (RHD).
- Customized painting.
- Other equipment available upon request.

Crane Introduction

Carrier

Driver's cab

- Vibration and external noise isolation.
- Equipped with pneumatic suspension seats with headrest, adjustable steering wheel, wide rear-view mirror, demister, HVAC, and stereo radio.
- The ergonomic design realizes safety and comfort.

Carrier frame

- Designed and manufactured by Sany, the torsion resistant box-type structure is welded by fine grain high-strength steel, featuring increased bearing capacity.

Engine

- Model: DF CUMMINS Inline six-cylinder diesel engine with watercooler and inter cooler.
- Emission standard: Euro III.
- Fuel reservoir capacity: 350L.

Transmission

- LHD: 9-speed MT with synchronizer; RHD: two options, 9-speed MT or 10-speed AMT both available.
- Large speed ratio range, adaptable to slope climbing and high-speed traveling.

Transmission shaft

- Optimized layout, higher torque output via contra gear connecting transmission shaft cardan.

Axle

- Axles 1, 2 are steered; axles 3, 4 are drive axles with built-in differential lock, coupled with two stage reducer and smaller size axle bags, realizing tougher ability to rough-terrain travelling. Press welding process strengthens the axle cover.

Suspension system

- Front suspension is realized by leaf spring, and rear rubber. With upgraded ride comfort, the suspension system is verified by 100,000 cycling fatigue tests, hence durability is out of question.

Steering

- Mechanical steering with hydro booster. Turn your steering wheel more easily.

Tires

- Radial tires sized 315/80R22.5, strong bearing capacity and durability.

Wheel formula

- 8 x 4 x 4.

Outrigger

- H-type layout, four point support, easy to operate, outrigger beam hydraulically telescoping, jack telescoping protected by two-way pilot controlled valve.

Brake

- Air servo functions on all wheels with diagonally split system.
- Service brake: air servo, double circuit split; wedge brake and double air chambers functioning on front axles.
- Parking brake: functioning at axles 3 and 4 by spring in air chamber.
- Emergency brake: performed by pressure reservoir.
- Assisting brake: engine exhaust brake, safety assured when driving down long slopes.

Electrical system

- 2*12V maintenance-free battery with a mechanical power switch, the overall power can be cut off manually. CAN instrument, data integration between superstructure and chassis.

Operating Range

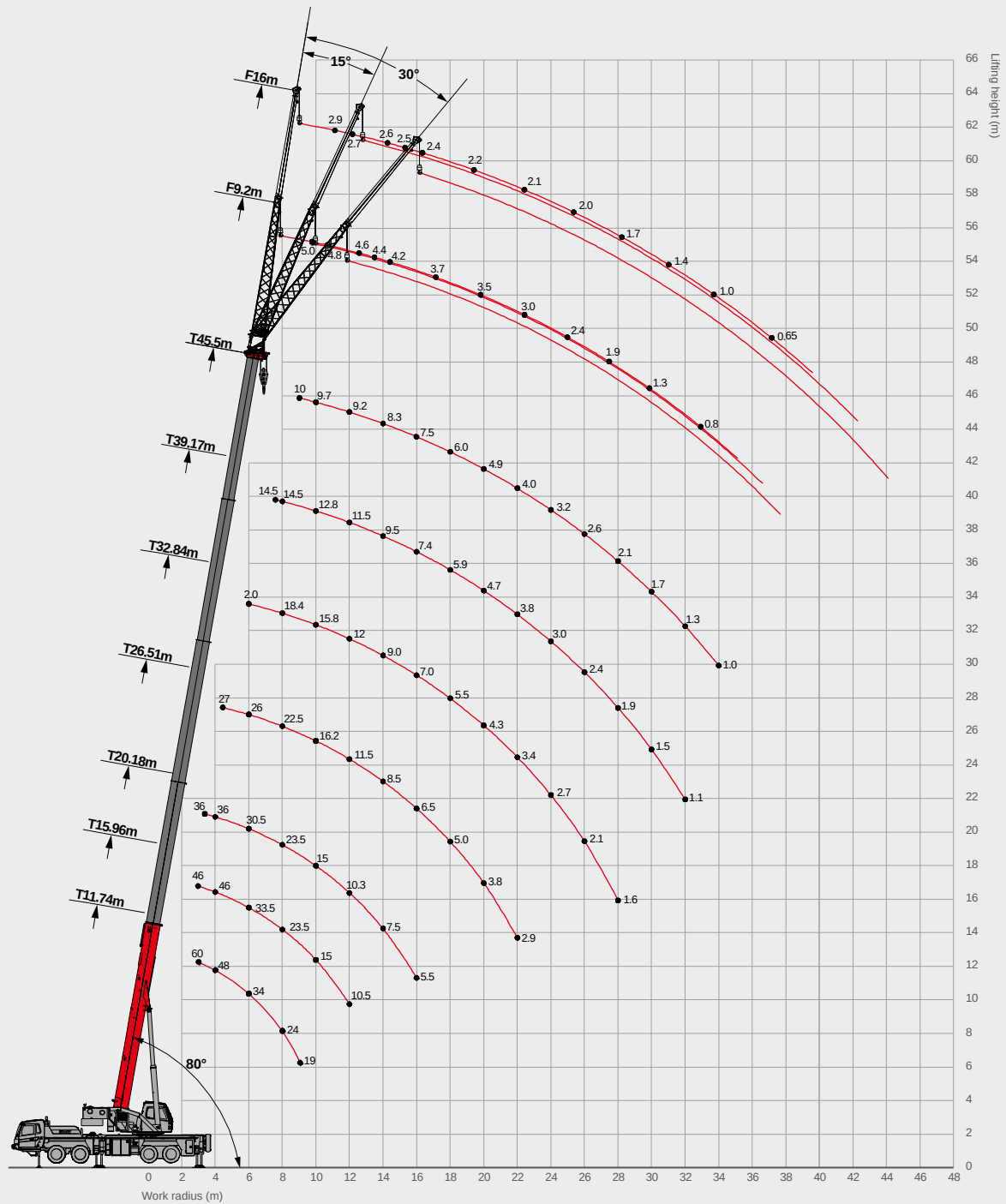

Load Chart-Telescopic Boom



Unit: kg

Radius (m)	11.7	16.0	20.2	26.5	32.8	39.2	45.5	18.1	24.4	30.7	37.1	22.3	28.6	35.0	41.3	Radius (m)
3	60000	46000						27000								3
3.5	55000	46000	36000					27000								3.5
4	48000	46000	36000					27000				27000				4
4.5	45000	44000	36000	27000				27000	24500			27000				4.5
5	43000	41000	34000	27000				27000	24500			27000	24000			5
5.5	38000	37000	32000	27000				27000	24000	18800		27000	24000			5.5
6	34000	33500	30500	26000	20000			27000	23000	18200		27000	24000			6
7	29000	28000	28500	24500	19500	14500		26500	21500	17000	11800	26500	23000	16500		7
8	24000	23500	23500	22500	18400	14500		25000	20000	15500	11800	25000	21000	15500	10500	8
9	19000	18500	18500	19500	17000	13600	10000	20500	18500	14000	11500	20000	19000	14500	10200	9
10		15000	15000	16200	15800	12800	9700	17000	17000	13000	10800	16500	17000	13500	10000	10
11		12500	12500	13500	14000	12000	9500	14300	15000	12000	10000	13700	14500	12500	9600	11
12		10500	10300	11500	12000	11500	9200	12200	12800	11000	9500	11700	12400	11600	9200	12
14			7500	8500	9000	9500	8300	9200	9800	9500	8200	8700	9300	9700	8400	14
16			5500	6500	7000	7400	7500		7700	8100	7200	6700	7300	7600	7600	16
18				5000	5500	5900	6000		6200	6600	6400	5200	5800	6200	6400	18
20				3800	4300	4700	4900		5000	5400	5600		4600	5000	5200	20
22				2900	3400	3800	4000			4500	4600		3700	4000	4300	22
24					2700	3000	3200			3700	3900		3000	3300	3600	24
26					2100	2400	2600			3100	3300			2700	3000	26
28					1600	1900	2100				2800			2200	2400	28
30						1500	1700				2300			1700	2000	30
32							1100	1300			2000				1600	32
34								1000							1300	34
36															1000	36
Telescoping status (%)																
2nd boom	0	50	100	100	100	100	100	0	0	0	0	50	50	50	50	2nd boom
3rd boom	0	0	0	25	50	75	100	25	50	75	100	25	50	75	100	3rd boom
4th boom	0	0	0	25	50	75	100	25	50	75	100	25	50	75	100	4th boom
5th boom	0	0	0	25	50	75	100	25	50	75	100	25	50	75	100	5th boom
Rope rate	12	10	8	6	5	4	3	6	5	4	3	6	5	4	3	Rope rate

Remark: rear and side operation.

Load Chart-Fixed Jib



Unit: kg

Telescopic boom + jib length(m)							
Boom angle(°)	45.5+9.2			45.5+16			Boom angle(°)
	0°	15°	30°	0°	15°	30°	
78°	5000	3300	2500	2900	1900	1400	78°
77°	4800	3200	2500	2700	1800	1350	77°
75°	4600	3100	2500	2600	1750	1300	75°
74°	4400	3000	2400	2500	1700	1250	74°
73°	4200	3000	2400	2400	1600	1200	73°
70°	3700	2800	2300	2200	1500	1150	70°
67°	3500	2600	2100	2100	1400	1100	67°
64°	3000	2300	1900	2000	1300	1050	64°
61°	2400	1900	1500	1700	1000	850	61°
58°	1900	1600	1350	1400	900	750	58°
55°	1300	1200	1100	1000	850	650	55°
51°	800	750	700	650	600	400	51°

Remark:

1. Value listed are the rated capacity when the crane is placed levelly on solid ground or surface.
2. When the fifth outrigger is landed in position, value listed are applicable for 360 degree operation.
3. Value above are calculated with hooks and lifting slings considered (551kg main hook block, 100kg aux. hook block).
4. Load value is given according to the larger radius or boom length value when the actual radius or boom length falls between two numbers above.
5. Rated load performance on boom point sheave shall be less than 5t; boom load capacity shall be 2300kg less than value given when jib unfolds.
6. Radius refers to actual radius with boom deflection considered.



SANY GROUP CRANE BU

SANY Mobile Crane Industrial Park, No.168 Jinzhou Avenue, Jinzhou Development Zone, Changsha City, Hunan Province, P.R. China Zip 410600

Consulting sanycrane@sanygroup.com (Crane BU) / crd@sany.com.cn (IHQ)

After-sales Service 0086-400 6098 318

Reminder:

Any change in the technical parameters and configuration due to product modification or upgrade may occur without prior notice. The machine in the picture may include additional equipment. This brochure is for reference only, and goods in kind shall prevail.

Copyright at SANY. No part of this brochure may be copied or used for any purpose without written approval from SANY.

© Edited in November 2022

